

## Models SSR-XV and SSR-XVM

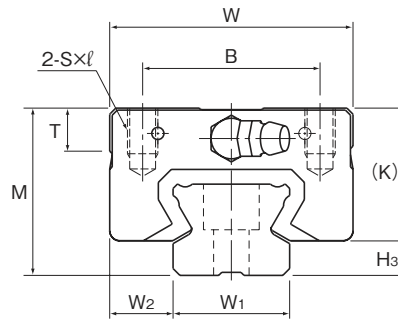

Model No.	Outer dimensions			LM block dimensions											Grease nipple	H <sub>3</sub>
	Height	Width	Length	B	S × ℓ	L <sub>1</sub>	T	K	N	E	f <sub>0</sub>	e <sub>0</sub>	D <sub>0</sub>			
	M	W	L	B	S × ℓ	L <sub>1</sub>	T	K	N	E	f <sub>0</sub>	e <sub>0</sub>	D <sub>0</sub>			
SSR 15XVY SSR 15XVMY	24	34	40.3	26	M4 × 7	23.3	6.5	19.5	4.5	5.5	2.7	4.5	3	PB1021B	4.5	
SSR 20XV SSR 20XVM	28	42	47.7	32	M5 × 8	27.8	8.2	22	5.5	12	2.8	5.2	3	B-M6F	6	
SSR 25XVY SSR 25XVMY	33	48	60	35	M6 × 9	36.8	8.4	26.2	6	12	3.3	7	3	B-M6F	6.8	

Note) Symbol M indicates that stainless steel is used in the LM block, LM rail and balls. Those models marked with this symbol are therefore highly resistant to corrosion and environment.

### Model number coding

**SSR25X V 2 UU C1 M +1200L Y P T M -III**

Model number	Type of LM block	Contamination protection accessory symbol (*1)	Stainless steel LM block	LM rail length (in mm)	Accuracy symbol (*3)	Stainless steel LM rail	Symbol for No. of rails used on the same plane (*4)
SSR25X	V	2	UU	C1	M	+1200L	Y P T M -III
	No. of LM blocks used on the same rail	Radial clearance symbol (*2) Normal (No symbol) Light preload (C1) Medium preload (C0)	Applied to only 15 and 25	Symbol for LM rail jointed use	Normal grade (No Symbol) High accuracy grade (H)/Precision grade (P) Super precision grade (SP)/Ultra precision grade (UP)		

(\*1) See contamination protection accessory on A-368. (\*2) See A-113. (\*3) See A-119. (\*4) See A-59.

Note) This model number indicates that a single-rail unit constitutes one set. (i.e., required number of sets when 3 rails are used in parallel is 3 at a minimum.)

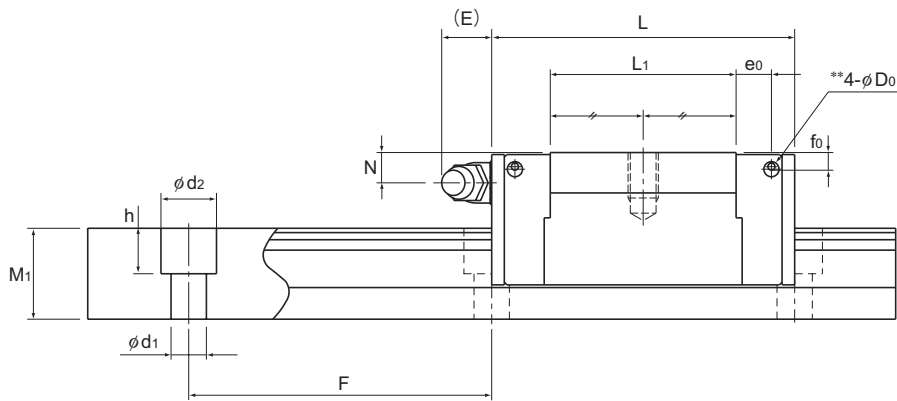

LM Guide

Unit: mm

	LM rail dimensions						Basic load rating		Static permissible moment kN-m*						Mass	
	Width	Height	Pitch		Length*	C	C <sub>0</sub>	M <sub>A</sub>		M <sub>B</sub>		M <sub>C</sub>	LM block	LM rail		
	W <sub>1</sub> ±0.05	W <sub>2</sub>	M <sub>1</sub>	F	d <sub>1</sub> × d <sub>2</sub> × h	Max	kN	kN	1 block	Double blocks	1 block	Double blocks	1 block	kg	kg/m	
	15	9.5	12.5	60	4.5 × 7.5 × 5.3	2500 (1240)	9.1	9.7	0.0303	0.192	0.0189	0.122	0.0562	0.08	1.2	
	20	11	15.5	60	6 × 9.5 × 8.5	3000 (1480)	13.4	14.4	0.0523	0.336	0.0326	0.213	0.111	0.14	2.1	
	23	12.5	18	60	7 × 11 × 9	3000 (2020)	21.7	22.5	0.104	0.661	0.0652	0.419	0.204	0.23	2.7	

Note1) Pilot holes for side nipples\*\* are not drilled through in order to prevent foreign material from entering the product. THK will mount grease nipples per your request. Therefore, do not use the side nipple pilot holes\*\* for purposes other than mounting a grease nipple.  
 The maximum length under "Length\*" indicates the standard maximum length of an LM rail. (See B-22.)  
 Static permissible moment\*: 1 block: static permissible moment value with 1 LM block  
 Double blocks: static permissible moment value with 2 blocks closely contacting with each other

Note2) The LM rail mounting hole of SSR15X is drilled for M4 screws as standard (with Y indication). If you order the hole to be drilled for M3 screws (without Y indication), contact THK. When replacing this model with model SR, pay attention to the dimension of the rail mounting hole.