



Change Nut

THK General Catalog

B Product Specifications

Dimensional Drawing, Dimensional Table
 Models DCMA and DCMB B-792

A Technical Descriptions of the Products (Separate)

Features	A-842
Features of the Change Nut.....	A-842
• Structure and features	A-842
• Features of the Special Rolled Shafts..	A-843
• High Strength Zinc Alloy	A-843
Point of Selection	A-845
Selecting a Change Nut	A-845
Efficiency, Thrust and Torque	A-849
Accuracy Standards	A-849
Point of Design	A-850
Fit	A-850
Mounting Procedure and Maintenance ...	A-851
Installation	A-851
Lubrication.....	A-852

* Please see the separate "A Technical Descriptions of the Products".

Models DCMA and DCMB

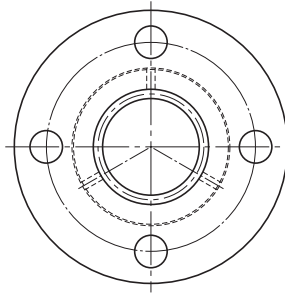

Change Nut Model No. ^(note)	Outer dimensions			Change nut dimensions							Screw shaft Model No. ^(note)
	Outer diameter		Length L	Flange diameter D ₁	H	B	PCD	r	F	d	
	D	Tolerance h9									
DCMB 8T ^(note)	15	0	16	28	4	3.4	21	0.8	—	—	CT 8T
DCMB 12T ^(note)	20	-0.1	25	36	5	4.5	27	1	—	—	CT 12T
DCMA 15T	22	0	15	44	6	5.4	31	1.5	4.5	1.5	CT 15T
DCMB 15T			30								
DCMA 17T	28	-0.052	15	51	7	6.6	38	1.5	4.5	1.5	CT 17T
DCMB 17T			35								
DCMA 20T	32	0	20	56	7	6.6	42	1.5	6.5	2	CT 20T
DCMB 20T			40								
DCMA 25T	36	-0.062	25	61	8	6.6	47	2	8.5	2	CT 25T
DCMB 25T			50								
DCMA 30T	44	0	28	76	10	9	58	2	9	2	CT 30T
DCMB 30T			56								
DCMA 35T	52	0	30	84	10	9	66	2.5	10	3	CT 35T
DCMB 35T			60								
DCMA 40	58	-0.074	35	98	12	11	76	2.5	11.5	3	☆ CT 40
DCMB 40			70								
DCMA 45	64	0	37	104	12	11	80	2.5	12.5	3	☆ CT 45
DCMB 45			75								
DCMA 50	68	0	40	109	12	11	85	2.5	14	3	☆ CT 50
DCMB 50			80								

Note) Symbol T indicates that a rolled shaft is used in combination with the change nut.

The dynamic permissible torque (T) and the dynamic permissible thrust (F) indicate the values at which the contact surface pressure on the screw teeth is 9.8 N/mm². Miniature Change Nut models DCMB8T and DCMB12T use oil-impregnated plastics. (outer diameter tolerance: special).

The screw shafts marked with "☆" are build-to-order.

The static permissible load (P) of the flange indicates the strength of the flange against the load as shown in the figure on the right.

Model number coding

Combination of change nut and screw shaft

2 DCMA20 +1500L T

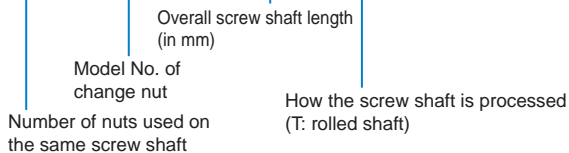

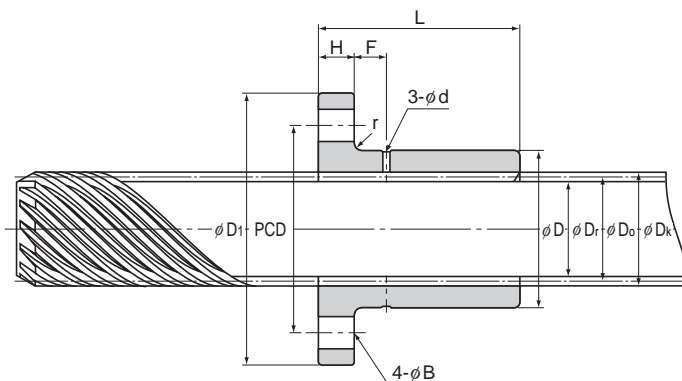

Unit: mm

Multi-thread screw shaft details							Standard shaft length	Maximum shaft length	Dynamic permissible torque T ^(note) N·m	Dynamic permissible thrust F ^(note) N	Static permissible load of the flange P ^(note) N	Mass	
Outer diameter D _k	Effective diameter D ₀	Thread minor diameter D _r	Lead R	Lead angle α °	Threaded grooves Z	Change nut g						Screw shaft kg/m	
9	7.6	6.2	24	(45)	6	500	1000	3.24	863	1800	5	0.36	
13.3	11.5	9.7	36	(45)	7	500,1000	1500	12.7	1370	2800	10	0.82	
15.8	13.7	11.6	44.4	(45)	8	500,1000	1500	16.7	2300	13800	60	1.2	
								32.4	4610		85		
17.8	15.7	13.6	50	(45)	9	500,1000	1500	20.6	2600	28100	95	1.5	
								48	6080		140		
21.2	18.7	16.2	60	(45)	9	500,1000,1500	3000	40.2	4170	34600	135	2.6	
								79.4	8330		210		
25.6	23.1	20.6	73.3	(45)	11	500,1000,1500	3000	74.5	6370	38500	175	3.3	
								148	12700		280		
31.9	29.4	26.9	93.3	(45)	14	500,1000,2000	4000	130	8090	55400	290	5.3	
								269	16200		465		
34.1	31.1	28.1	97.7	(45)	11	500,1000,2000	4000	144	9260	84500	425	5.8	
								287	18500		670		
44	38.18	33.3	119.9	(45)	12	500,1000,2000	—	381	20000	85200	715	9	
								763	40000		1065		
47	41.37	36.4	129.9	(45)	13	1000,2000,3000	—	474	22900	115000	820	10.6	
								960	46600		1270		
52	47.73	42.9	149.9	(45)	15	1000,2000,3000	—	681	28500	108000	925	14	
								1360	57100		1375		

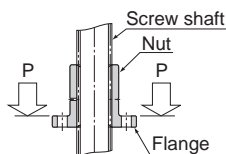

Model number coding

Multi-thread screw shaft

CT20 T +1500L

How the screw shaft is processed (T: rolled shaft) Overall screw shaft length (in mm)

Model number of screw shaft

Change Nut

