



LM Stroke

THK General Catalog

A Technical Descriptions of the Products

LM Stroke Models ST, ST-B, STI	A-554
Structure and features.....	A-554
Types and Features	A-555
Rated Load and Nominal Life.....	A-556
Accuracy Standards	A-558
Fit	A-559
ST shaft.....	A-559
Installation of the ST Shaft.....	A-559

Miniature Stroke Model MST	A-560
Structure and features.....	A-560
Fit	A-561
Travel Distance of the Ball Cage.....	A-561

Die-setting Ball Cage Models KS and BS ...	A-562
Structure and features.....	A-562
Rated Load and Service Life	A-562
Fit	A-563
Installation of the Ball Cage	A-563

Precautions on Use	A-564
---------------------------------	-------

B Product Specifications (Separate)

Dimensional Drawing, Dimensional Table..	B-463
LM Stroke Models ST, ST-B and STI	
• Models ST and ST-B	B-464
• Models ST…UU and ST…UUB	B-468
Miniature Stroke Model MST	
• Model MST.....	B-472
Die-setting Ball Cage Models KS and BS	
• Models KS / BS	B-474

* Please see the separate "B Product Specifications".

LM Stroke

Models ST, ST-B and STI

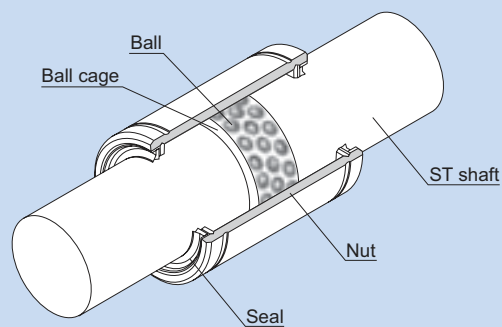

Fig.1 Structure of LM Stroke Model ST

Structure and Features

Model ST has a ball cage and balls both incorporated into a precision-ground cylindrical nut as shown in Fig.1. The balls are arranged in zigzags so as to evenly receive a load. The ball cage is a drilled cage made of a light alloy with high rigidity, and is capable of high-speed motion. A thrust ring and a snap ring are installed on both sides of the inner surface of the nut to prevent the ball cage from overshooting.

This structure allows rotational motion, reciprocal motion and complex motion with a small friction coefficient. Model ST has a stroke length up to twice the range within which the ball cage can travel. Since high accuracy can be obtained at a low price, this model is used in a broad array of applications such as press die setting, ink roll unit of printing machine, workpiece chuck unit of punching press, press feeder, work head of electric discharge machine, wound roll corrector, spinning and weaving machine, distortion measuring equipment, spindle of optical measuring instrument, and photocopiers.

Features of Each Model

LM Stroke

[Minimal Friction Coefficient]

The balls and the ball raceway are in point contact, which causes the smallest rolling loss, and the balls are individually retained in the ball cage. This allows the LM stroke to perform rolling motion at a minimal friction coefficient ($\mu=0.0006$ to 0.0012).

[Compact Design]

Since it consists only of a thin nut and balls, the outer diameter of the bearing is minimized and a light, space-saving, compact design is achieved.

[High Accuracy at a Low Price]

A highly accurate slide unit can be produced at a low price.

Types and Features

Light Load Type Model ST

Specification Table⇒B-464

Model ST is a light load type that allows for a long stroke.

Shaft diameter: $\phi 6$ to $\phi 100$

In addition, a type attached with seal is available. Model ST-UU

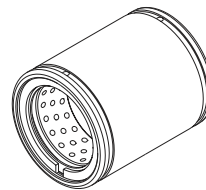

Model ST

LM Stroke

Medium Load Type Model ST-B

Specification Table⇒B-464

It has the same dimensions as model ST, but has a shorter stroke and achieves a rated load twice that of ST.

Shaft diameter: $\phi 8$ to $\phi 100$

In addition, a type attached with seal is available. Model ST-UUB

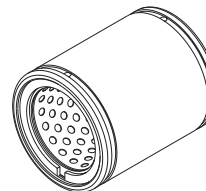

Model ST-B

Inner Ring Type Model STI

If the LM shaft cannot be hard quenched, STI allows an inner ring to be incorporated. The inner ring is available build-to-order.

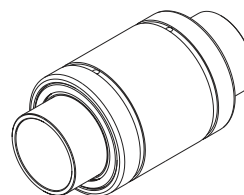

Model STI

Rated Load and Nominal Life

[Load Rating]

The basic load ratings for model ST are indicated in the respective specification tables.

[Nominal Life]

The nominal life of model ST is obtained using the following equation.

$$L = \left(\frac{f_H \cdot f_T \cdot f_C}{f_W} \cdot \frac{C}{P_C} \right)^3$$

- L : Nominal life (rotating 10^6 times)
 (The total number of revolutions that 90% of a group of identical LM strokes independently operating under the same conditions can achieve without showing flaking)
- C : Basic dynamic load rating (kN)
- P_C : Calculated radial load (kN)
- f_H : Hardness factor (see Fig.2 on A-557)
- f_T : Temperature factor (see Fig.3 on A-557)
- f_C : Contact factor (see Table1 on A-558)
- f_W : Load factor (see Table2 on A-558)

[Calculating the Service Life Time]

When the nominal life (L) has been obtained, if the number of revolutions per minute and the number of reciprocations per minute are constant, the service life time is obtained using the following equation.

● For Rotating Motion or Complex Motion

$$L_h = \frac{10^6 \times L}{60 \sqrt{(dm \cdot n)^2 + (10 \times \alpha \cdot \ell_s \cdot n_r)^2} / dm}$$

● For Reciprocating Motion

$$L_h = \frac{10^6 \times L}{60 \times 10 \times \alpha \cdot \ell_s \cdot n_r / (\pi \cdot dm)}$$

- L_h : Service life time (h)
- n : Revolutions per minute (min^{-1})
- n_r : Number of reciprocations per minute (min^{-1})
- ℓ_s : Stroke length (mm)
- dm : Pitch circle diameter (mm)
 ($dm \cong 1.15 \times dr$)
- dr : Ball inscribed bore diameter (mm)
- α : Factor for cage material ($\alpha=0.7$)

Features of Each Model

LM Stroke

[Tolerance Value in Rotation and Reciprocating Speed]

The permissible speed limit of model ST is obtained using the following equation.

$$DN \geq dm \cdot n + 10 \times l_s \cdot n_1$$

For the DN value above, the following value applies as a standard value.

For oil lubrication DN=600000

For grease lubrication DN=300000

However, the following points must be taken into account.

$$n_1 \leq 5000$$

$$l_s \cdot n_1 \leq 50000$$

● f_H : Hardness Factor

To maximize the load capacity of model ST, the hardness of the raceways needs to be between 58 to 64 HRC.

If the hardness is lower than this range, the basic dynamic load rating and the basic static load rating decrease. Therefore, it is necessary to multiply each rating by the respective hardness factor (f_H).

Normally, $f_H=1.0$ since model ST has sufficient hardness.

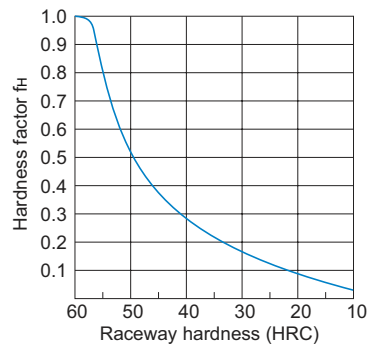

Fig.2 Hardness Factor (f_H)

● f_T : Temperature Factor

If the temperature of the environment surrounding the operating model ST exceeds 100°C, take into account the adverse effect of the high temperature and multiply the basic load ratings by the temperature factor indicated in Fig.3.

Note) If the environment temperature exceeds 80°C, contact THK.

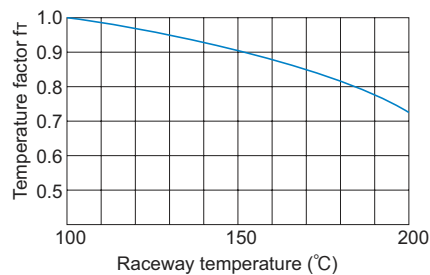

Fig.3 Temperature Factor (f_T)

LM Stroke

● **f_c: Contact Factor**

When multiple nuts of model ST are used in close contact with each other, their linear motion is affected by moments and mounting accuracy, making it difficult to achieve uniform load distribution. In such applications, multiply the basic load rating (C) and (C₀) by the corresponding contact factor in Table1.

Note) If uneven load distribution is expected in a large machine, take into account the respective contact factor indicated in table 1.

Table1 Contact Factor (f_c)

Number of nuts in close contact with each other	Contact factor f _c
2	0.81
3	0.72
4	0.66
5	0.61
Normal use	1

● **f_w: Load Factor**

In general, reciprocating machines tend to involve vibrations or impact during operation. It is extremely difficult to accurately determine vibrations generated during high-speed operation and impact during frequent start and stop. Therefore, when speed and vibrations have a significant influence, divide the basic dynamic load rating (C or C₀), by the corresponding load factor in Table2 of empirically obtained data.

Table2 Load Factor (f_w)

Vibrations/ impact	Speed(V)	f _w
Faint	Very low V ≤ 0.25m/s	1 to 1.2
Weak	Slow 0.25 < V ≤ 1m/s	1.2 to 1.5
Medium	Medium 1 < V ≤ 2m/s	1.5 to 2
Strong	High V > 2m/s	2 to 3.5

Accuracy Standards

The tolerance value in inscribed bore diameter (dr), nut outer diameter (D) and nut length (L) is indicated in the corresponding specification table.

The end of the nut may be deformed due to tension of the snap ring. Therefore, when measuring the nut outer diameter, it is necessary to calculate the measurement range using the following equation, and obtain the average diameter value within the range.

The tolerance value in the nut outer diameter is equal to the calculated average value of the maximum diameter and the minimum diameter obtained through two-point measurement of the outer diameter.

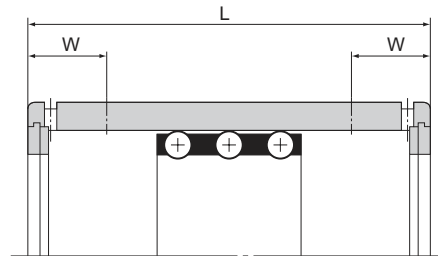

Fig.4 Measurement Range of the Nut

$$W = 4 + \frac{L}{8}$$

W : Length out of the measurement range (mm)
L : Nut length (mm)

Fit

In theory, the ball cage of model ST moves in the same direction as the ST shaft by 1/2 of the shaft (or nut). However, to minimize the travel distance error caused by uneven load distribution or vibrations, it is necessary to reduce the clearance. If high accuracy is required or if the LM Stroke is used on a vertical shaft, we recommend setting the radial clearance between 0 and 10 μm .

Item	Normal conditions	Vertical shaft or high accuracy
ST shaft	k5, m5	n5, p5
Housing	H6, H7	J6, J7

ST Shaft

With the ST shaft, used in model ST, balls roll directly on the shaft surface. Therefore, it is necessary to pay much attention to the hardness, surface roughness and dimensional accuracy when manufacturing it.

Since the hardness of the ST shaft has especially large impact on the service life, use much care in selecting a material and heat treatment method.

THK also manufactures high-quality ST shafts. Contact us for details.

[Material]

Generally, the following materials are used as suitable for surface hardening through induction-hardening.

- SUJ2 (JIS G 4805: high-carbon chromium bearing steel)
- SK3 to 6 (JIS G 4401: carbon tool steel)
- S55C (JIS G 4051: carbon steel for machine structural use)

[Hardness]

We recommend surface hardness of 58 HRC (\approx 653 HV) or higher. The depth of the hardened layer is determined by the shaft diameter; we recommend approximately 2 mm for general use.

The ST shaft can have a hardened inner ring attached on the shaft raceway.

[Surface Roughness]

To achieve smooth motion, the surface is normally finished to 0.40a or less. If higher wear resistance is required, finish the surface to 0.20a or less.

Installation of the ST Shaft

To install the ST shaft, drive it in to the designated depth. If the clearance is negative, a large driving force is required. However, do not forcibly hammer the shaft. Instead, apply a lubricant on the ST shaft first, and then gradually drive it in with a slight back action.

Miniature Stroke

Model MST

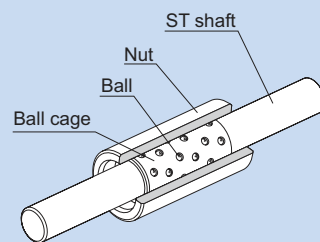

Fig.1 Structure of Miniature Stroke Model MST

Structure and Features

Model MST consists of an ST shaft, ball cage and nut. These components can freely be combined according to the application. The sectional shape is small, the clearance is minimal and the motion is extremely light and smooth. Accordingly, model MST can be used in a variety of small, precision measuring equipment such as optic measuring instrument's spindle, pen plotter, OA equipment, computer terminals, automatic scale, digital length measuring machine and solenoid valve.

[Highly Accurate Bearing]

Precision steel balls (sphericity in mutual difference: 0.0003 mm) compliant with JIS B 1501 are incorporated in a copper alloy ball cage to ensure high accuracy. The ball cage serves to prevent the balls from falling off with a unique ball-retaining design.

[Highly Durable Bearing]

The nut of the ST shaft uses a selected material, and is heat-treated and ground. In addition, the raceways are finished with ultra fine finish. The rows of balls are densely arranged in the ball cage, and the balls are placed so that the ball raceways do not overlap with each other. It enables this model to be used over a long period without wear and to demonstrate high durability.

Features of Each Model

Miniature Stroke

[Compact Bearing]

Use of a combination of balls with a 1 mm diameter and a thin nut allows a small sectional shape and space-saving design.

[Bearing with Extremely Low Frictional Resistance]

Since the balls are in point-contact with the raceways, rolling loss is minimal and rolling motion with low-friction is achieved.

Fit

The inner surface of the housing must be finished to H6 to H7, and secured with an adhesive after the nut is inserted.

When press fitting is required, mounting the nut to the hole will reduce the inner diameter. Therefore, be sure to check the inner diameter after press fitting the nut and adjust the shaft diameter so that a correct preload is achieved. Also make sure that the preload must not exceed $-2\mu\text{m}$.

Travel Distance of the Ball Cage

The ball cage can travel up to 1/2 of the stroke length (l_s) of the nut or the ST shaft in the same direction.

LM Stroke

Die-setting Ball Cage

Models KS and BS

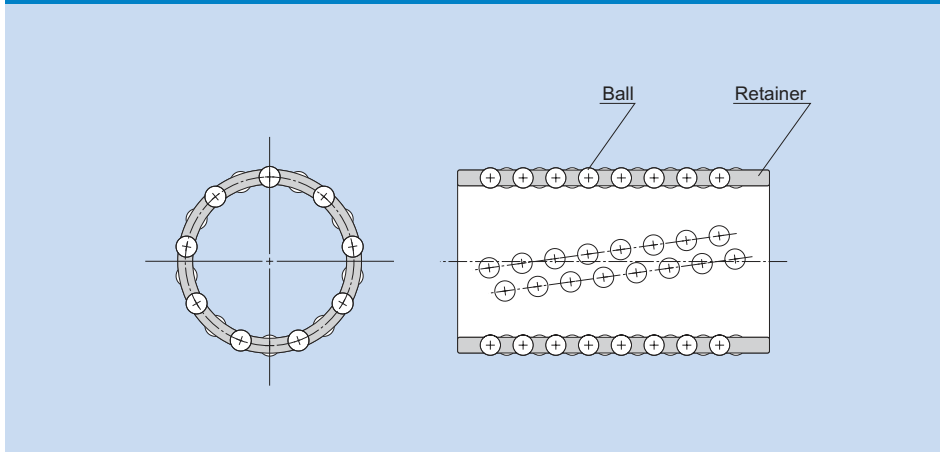

Fig.1 Structure of Die-setting Ball Cage Model KS

Structure and Features

With models KS and BS, a large number of precision steel balls (sphericity in mutual difference: 0.0005 mm) compliant with JIS B 1501 are incorporated in a lightweight, highly rigid ball cage. The balls are arranged along the circumference of the ball cage in spirals so that the ball raceways do not overlap with each other. It enables these models to be used over a long period without wear and to demonstrate high durability.

In addition, the ball pockets, which hold the balls, are finished with precision and continuously caulked with a unique process, enabling them to prevent the balls from falling. It allows the system to travel smoothly even if the ball cage is longer than the housing.

These ball cages are used in precision press die set, spinning and weaving machine, precision measuring instrument, automatic recorder, medical equipment and various machine tools.

Rated Load and Service Life

The rated loads of models KS and BS are indicated in the respective specification tables. Their service lives are obtained using the service life equation for LM Stroke model ST on A-556.

Features of Each Model

Die-setting Ball Cage

Fit

When using the Die-setting Ball Cage in the guide unit of the guide post of a precision press die set, normally select a negative clearance in order to increase the accuracy and the ball cage rigidity. Table1 shows typical fitting between the hole and the shaft. Select a combination of a hole and a shaft so that the clearance does not

exceed the tolerance value of the radial clearance indicated in the specification table.

Table1 Fitting between Holes and Shaft

Tolerance in hole dimensions: D	K5
Dimensional tolerance of the shaft: d	h5

Installation of the Ball Cage

Fig.2 shows examples of mounting the Die-setting Ball Cage.

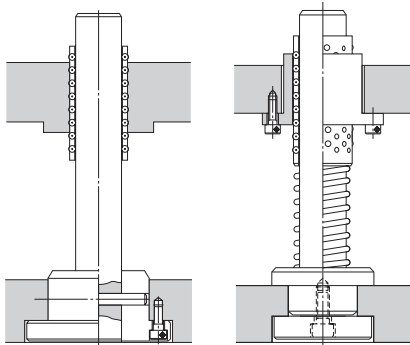

Fig.2 Example of Installation

LM Stroke

[Handling]

- (1) Disassembling components may cause dust to enter the system or degrade mounting accuracy of parts. Do not disassemble the product.
- (2) Dropping or hitting the LM Stroke may damage it. Giving an impact force to the product could also cause damage even if the product looks intact.

[Lubrication]

- (1) LM Stroke model ST can use either oil or grease as a lubricant. Select either lubricant according to the DN value. When using grease, we recommend high-quality lithium-soap group grease No. 2.
- (2) Thoroughly remove anti-rust oil and feed lubricant before using the product.
- (3) Do not mix lubricants of different physical properties.
- (4) In locations exposed to constant vibrations or in special environments such as clean rooms, vacuum and low/high temperature, normal lubricants may not be used. Contact THK for details.
- (5) When planning to use a special lubricant, contact THK before using it.

[Precautions on Use]

- (1) Entrance of foreign material into LM Stroke model ST may cause abnormal wear or shorten the service life. When entrance of foreign material is predicted, it is important to select an effective sealing device or dust-control device that meets the environment conditions. For LM Stroke model ST, a special synthetic rubber seal (ST···UU) that is highly resistant to wear and a felt seal with high contamination protection effect and low seal resistance (ST···DD) are available for some types as contamination protection accessories.
- (2) If foreign material adheres to the product, replenish the lubricant after cleaning the product.
- (3) Contact THK if you desire to use the product at a temperature of 80°C or higher.
- (4) Please be careful when using the product in an environment with excessive coolant. The coolant may cause premature failure if it penetrates the bushing nut. Contact THK for further details.
- (5) When using the product in locations exposed to constant vibrations or in special environments such as clean rooms, vacuum and low/high temperature, contact THK in advance.

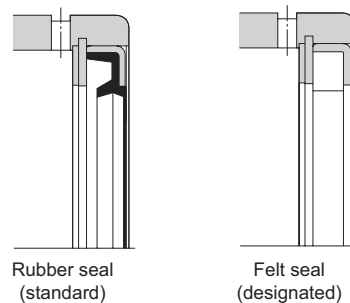

Fig.1 Types of the Seal for the LM Stroke

[Storage]

When storing the LM Stroke, enclose it in a package designated by THK and store it while avoiding high temperature, low temperature and high humidity.