

# Cross Roller Table

**THK** General Catalog

## A Technical Descriptions of the Products

<b>Features and Types</b> .....	A-586
Features of the Cross Roller Table ...	A-586
• Structure and features.....	A-586
<b>Point of Selection</b> .....	A-588
Rated Load and Nominal Life.....	A-588
Accuracy Standards .....	A-590
<b>Precautions on Use</b> .....	A-591

## B Product Specifications (Separate)

<b>Dimensional Drawing, Dimensional Table..</b>	B-501
Model VRT Miniature Type (Tapped Base Type).....	B-502
Model VRT-A Miniature Type (Tapped Base Type) ..	B-504
Model VRU .....	B-506

\* Please see the separate "B Product Specifications".

## Features of the Cross Roller Table

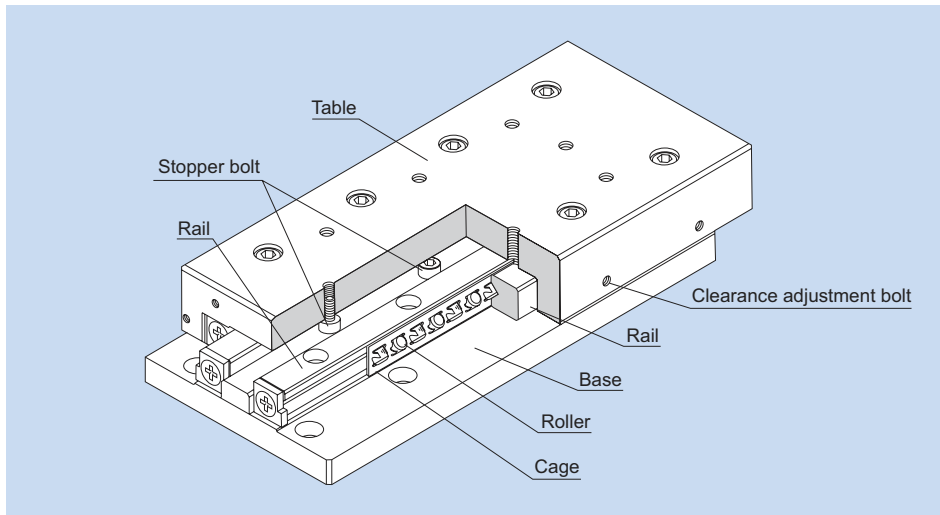

Fig.1 Structure of the Cross Roller Table

### Structure and Features

The Cross Roller Table is a compact, highly rigid finite linear guide unit that has the Cross Roller Guide(s) between the precision-machined table and base.

There are two types of the Cross Roller Table: model VRU, and a miniature type model VRT. The Cross Roller Table is used in extensive applications such as OA equipment and peripherals, measuring instruments and printed circuit board drilling machines.

## Features and Types

### Features of the Cross Roller Table

#### [Easy Installation]

Since the Cross Roller Guide(s) is installed between the precision-machined table and base, a highly accurate linear guide mechanism is achieved simply by mounting the product with bolts.

#### [Large Permissible Load]

Since rollers with large rated loads are installed in short pitches, the cross roller guide is capable of bearing a heavy load, achieving a highly rigid linear guide mechanism and gaining a long service life.

#### [Diversified Usage]

Since the rollers are orthogonally arranged one after another, the guide system is capable of evenly receiving loads in the four directions applied on the table. (See Fig.2.)

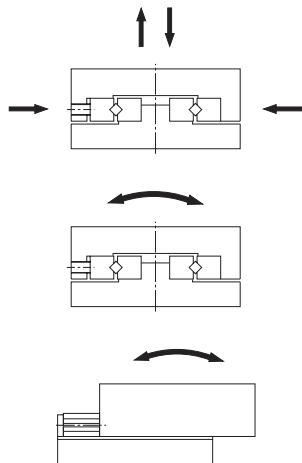
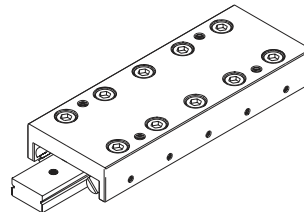

Fig.2 Load Directions

#### [Highly Corrosion Resistant]

The base and the table of models VRT-M and VRT-AM use stainless steel. Their rails, rollers, roller cages and screws are also made of stainless steel. As a result, these guide systems have significantly high corrosion resistance.

The base and the table of model VRU-M are made of aluminum.



Model VRT

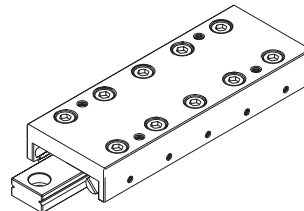

Model VRT-A

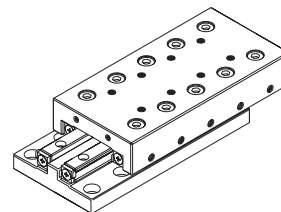

Model VRU



Cross Roller Table

## Rated Load and Nominal Life

### [Rated Loads in All Directions]

The rated loads of models VRT, VRT-A and VRU are equal in four directions (radial, reverse radial and lateral directions), and their values are expressed as C and C<sub>0</sub> in the corresponding specification tables.

### [Static Safety Factor f<sub>s</sub>]

The Cross Roller Table may receive an unexpected external force while it is stationary or operative due to the generation of an inertia caused by vibrations and impact or start and stop. It is necessary to consider a static safety factor against such a working load.

$$f_s = \frac{C_0}{P_c} \quad \text{or} \quad f_s = \frac{M_0}{M}$$

- f<sub>s</sub> : Static safety factor
- C<sub>0</sub> : Basic static load rating (kN)
- M<sub>0</sub> : Static permissible moment (M<sub>A</sub>, M<sub>B</sub> and M<sub>C</sub>)
- P<sub>c</sub> : Calculated load (kN)
- M : Calculated moment (kN)

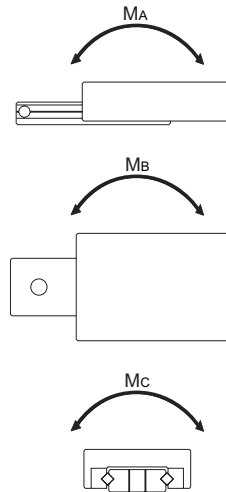

### ● Reference value of static safety factor

The static safety factors indicated in Table1 are the lower limits of reference values in the respective conditions.

Table1 Reference Values of Static Safety Factor (f<sub>s</sub>)

Machine using the LM system	Basic dynamic load rating	Lower limit of f <sub>s</sub>
General industrial machinery	Without vibration or impact	1 to 1.3
	With vibration or impact	2 to 3

## Point of Selection

### Rated Load and Nominal Life

#### [Nominal Life]

The nominal life of the Cross Roller Table is obtained using the following equation.

$$L = \left( \frac{f_r}{f_w} \cdot \frac{C}{P_c} \right)^{\frac{10}{3}} \times 100$$

- L : Nominal life (km)  
(The total number of revolutions that 90% of a group of identical VRT, VRT-A or VRU units independently operating under the same conditions can achieve without showing flaking)
- C : Basic dynamic load rating (kN)
- P<sub>c</sub> : Calculated radial load (kN)
- f<sub>r</sub> : Temperature factor  
(see Fig.1 on A-590)
- f<sub>w</sub> : Load factor (see Table2 on A-590)

#### [Calculating the Service Life Time]

When the nominal life (L) has been obtained, if the stroke length and the number of reciprocations per minute are constant, the service life time is obtained using the following equation.

$$L_h = \frac{L \times 10^6}{2 \times l_s \times n_1 \times 60}$$

- L<sub>h</sub> : Service life time (h)
- l<sub>s</sub> : Stroke length (mm)
- n<sub>1</sub> : Number of reciprocations per minute (min<sup>-1</sup>)

● **f<sub>t</sub>: Temperature Factor**

If the temperature of the environment surrounding the operating model VRT, VRT-A or VRU exceeds 100 °C, take into account the adverse effect of the high temperature and multiply the basic load ratings by the temperature factor indicated in Fig.1.

Note) If the environment temperature exceeds 100 °C, contact THK.

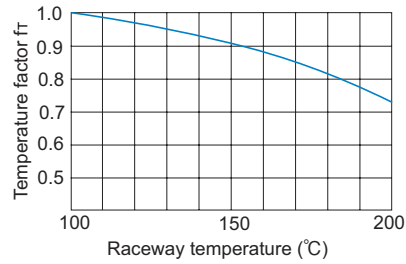

Fig.1 Temperature Factor (f<sub>t</sub>)

● **f<sub>w</sub>: Load Factor**

In general, reciprocating machines tend to involve vibrations or impact during operation. It is extremely difficult to accurately determine vibrations generated during high-speed operation and impact during frequent start and stop. Therefore, when the actual load applied on model VRT, VRT-A or VRU cannot be obtained, or when speed and vibrations have a significant influence, divide the basic load rating (C or C<sub>0</sub>), by the corresponding load factor in Table2 of empirically obtained data.

Table2 Load Factor (f<sub>w</sub>)

Vibrations/impact	Speed(V)	f <sub>w</sub>
Faint	Very low V ≤ 0.25m/s	1 to 1.2
Weak	Slow 0.25 < V ≤ 1m/s	1.2 to 1.5

## Accuracy Standards

The dimensional tolerances of Cross Roller Table models VRT, VRT-A and VRU in height (M) and width (W), and the running accuracy of the base against the mounting surfaces C and D are indicated in the corresponding specification tables.

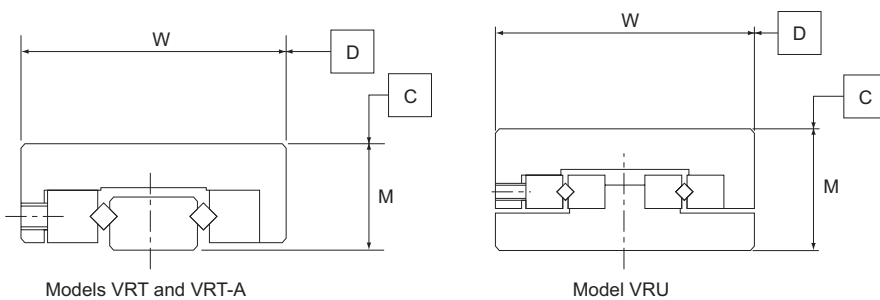

Fig.2 Accuracy Standards

### [Handling]

- (1) Disassembling components may cause dust to enter the system or degrade mounting accuracy of parts. Do not disassemble the product.
- (2) Dropping or hitting the Cross Roller Table may damage it. Giving an impact to it could also cause damage to its function even if the product looks intact.

### [Lubrication]

- (1) For lubrication of the Cross Roller Table, use lithium-soap group grease or oil when it is necessary as with ordinary bearings.
- (2) Thoroughly remove anti-rust oil and feed lubricant before using the product.
- (3) Do not mix lubricants of different physical properties.
- (4) In locations exposed to constant vibrations or in special environments such as clean rooms, vacuum and low/high temperature, normal lubricants may not be used. Contact THK for details.
- (5) When planning to use a special lubricant, contact THK before using it.

### [Additional Machining of the Table and the Base]

When additionally machining the table and the base of the Cross Roller Table according to the conditions such as drilling mounting holes, adhere to the following precautions.

- (1) Do not let cutting chips enter the Cross Roller Guide unit.
- (2) Machine the mounting holes as blind holes, not through holes.  
THK can perform additional machining such as mounting holes as requested.

The clearance of the Cross Roller Table is adjusted to the appropriate preload. Do not touch the clearance adjustment screw.

### [Offset of the Cage]

The cage, which retains rollers (or balls), demonstrates extremely accurate motion. However, it may be offset as affected by driving vibrations, inertia or impact.

If using the Cross Roller Guide or Ball Guide in the following conditions, contact THK.

- Vertical use
- Pneumatic cylinder drive
- Cam drive
- High speed crank drive
- Under a large moment load
- Butting the guide's external stopper with the table

**[Precautions on Use]**

- (1) Entrance of foreign material may cause damage to the ball circulating component or functional loss. Prevent foreign material, such as dust or cutting chips, from entering the system.
- (2) If foreign material adheres to the product, replenish the lubricant after cleaning the product.
- (3) Contact THK if you desire to use the product at a temperature of 100°C or higher.
- (4) When using the product in locations exposed to constant vibrations or in special environments such as clean rooms, vacuum and low/high temperature, contact THK in advance.

**[Storage]**

When storing the Cross Roller Table, enclose it in a package designated by THK and store it while avoiding high temperature, low temperature and high humidity.